



## **EBSRAY PUMPS**



**EHS Horizontal**

**Single Stage Split Case Pump**

- ⊗ GENERAL INDUSTRY & PROCESS
- ⊗ BUILDING SERVICES & HVAC
- ⊗ AGRICULTURE & IRRIGATION
- ⊗ FIRE PROTECTION
- ⊗ WATER SUPPLY & BOOSTERS

## EHS Series

### Description

EHS horizontal double-suction split-casing pump is our advanced new product. Pump casing is in nice linearity design with stiffeners. The two bearings are located at a short distance, and the shaft is accordingly shortened, so that shaft, bearings and mechanical seals would be kept in a long service life. Shaft is fully sealed away from medium, no erosion, and high interchangeability. Closed circulate cooling system is applied to its inner seal housing, which makes EHS pump simple in structure and easy to maintain. EHS split-casing pumps are used far and wide in civil water supply, industry, construction, air-conditioning, irrigation, marine, fire fighting and power station.

**Structure:** Single-Stage, Double Suction, Split-Casing, Centrifugal Pump

**Flange:** DIN2501 (ISO7005.2 or GB/T17241.6 PN 1.6) standard, ANSI B 16.5 Class 150lb optional

### Material

- Casing - Cast Iron standard, Ductile Iron, Stainless Steel optional
- Impeller - Bronze standard, Cast Iron, Stainless Steel optional
- Shaft - ASTM1045 standard, ASTM420, ASTM304, ASTM316 optional
- Shaft Seal - Mechanical Seal standard  
(Carbon-Ceramic/Viton standard, Carbon-Sic/Viton optional),  
Gland Packing optional

### Operating Data

- Discharge diameter : 80–600mm
- Max Capacity : 2000 l / s
- Max Head : 170m
- Max Pressure : 16 Bar standard,  
25 Bar on request
- Max Temperature : 105°C

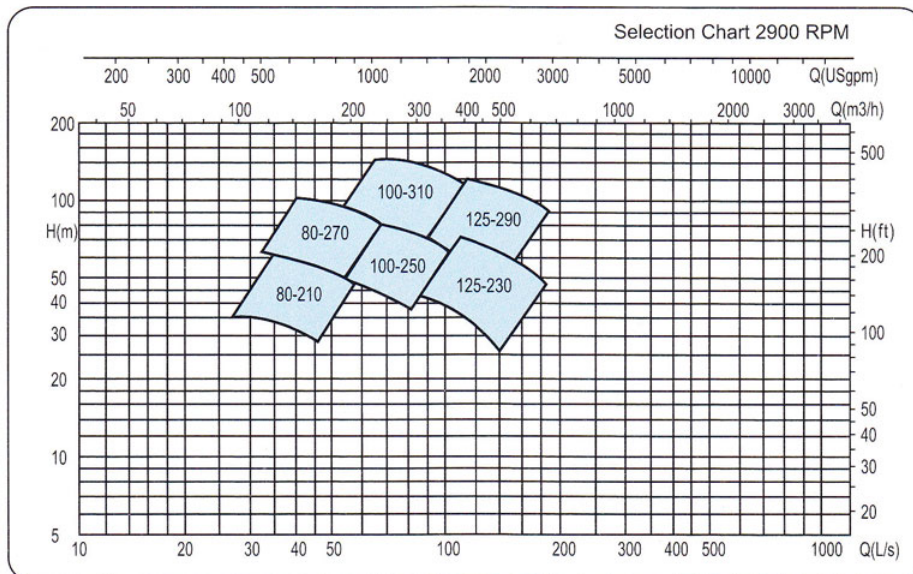
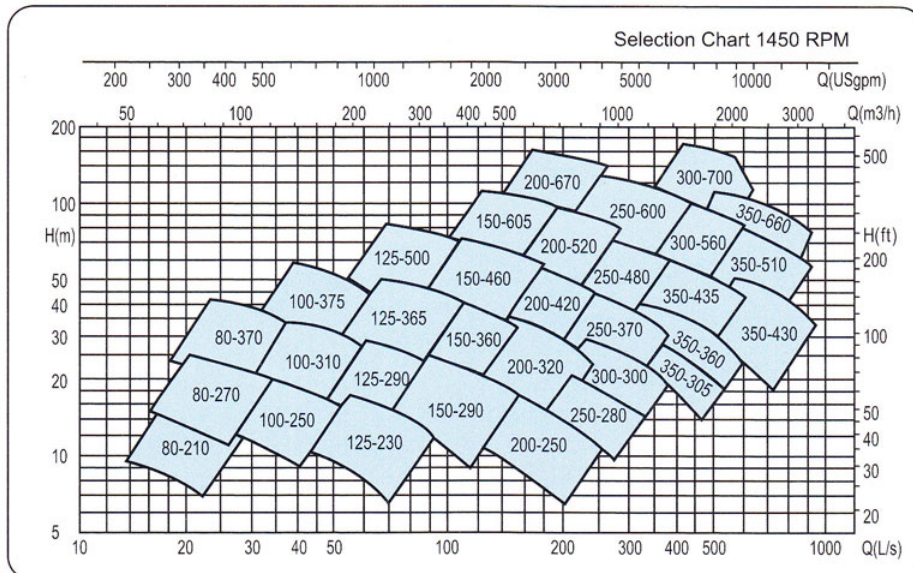

Due to the policy of constant research and development, specifications may change without notice.

# EHS SERIES

## Rotation

Standard Type: Clockwise viewing from the drive side

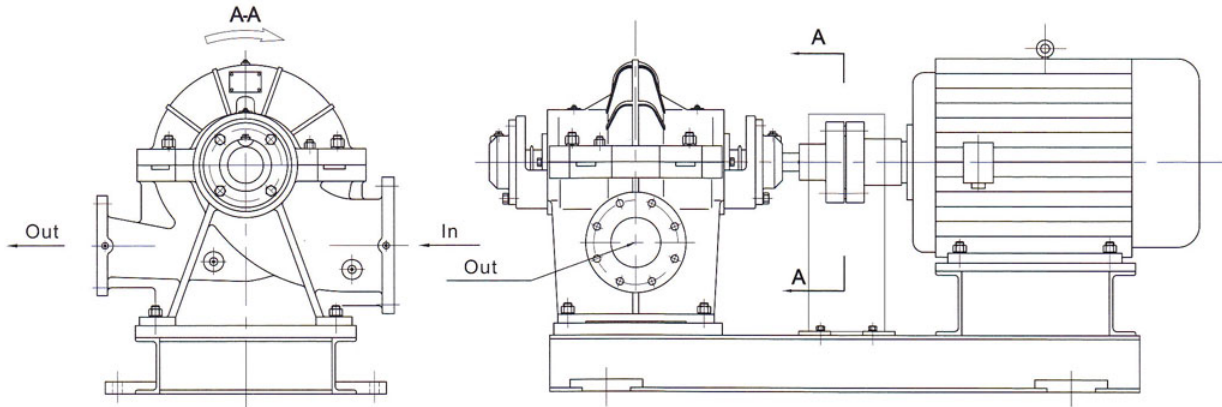

Special Type: Counter-Clockwise viewing from the drive side

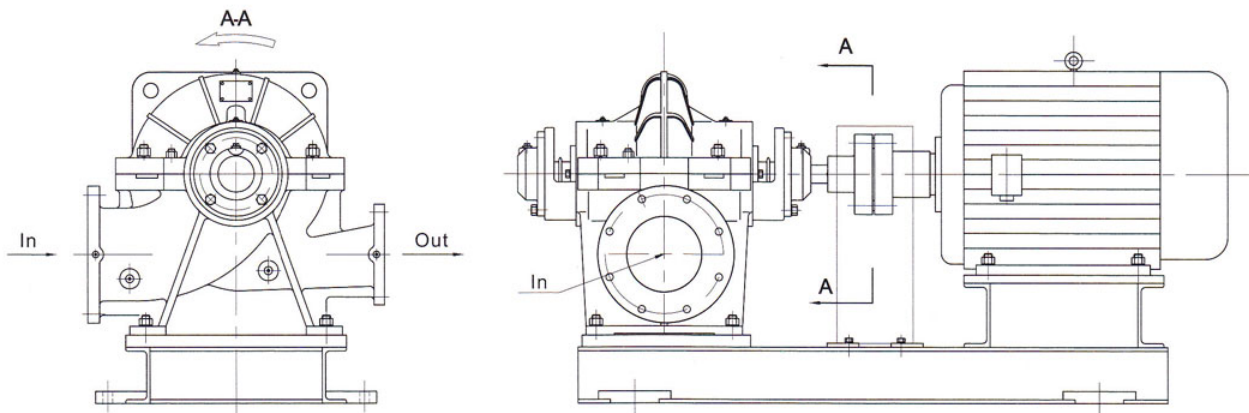

## EHS Outline Drawing & Installing Dimensions

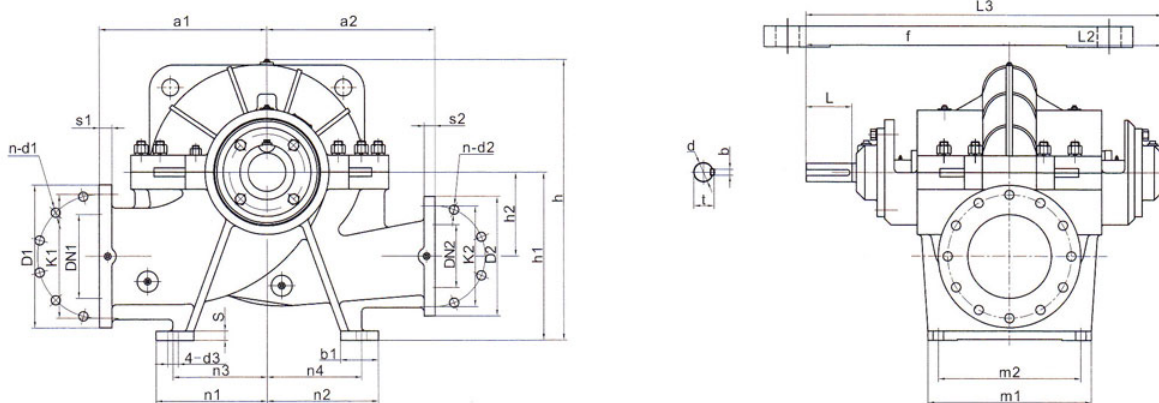

## Dimension Sheet For Single Stage Horizontal Split Case Pumps

No	Model	Flange		Pump body								Foot								Shaft				
		DN1	DN2	a1	a2	f	l2	l3	h	h1	h2	m1	m2	n1	n2	n3	n4	b1	d3	s	d	b	l	t
1	EHS80-210	125	80	300	300	385	300	685	480	315	140	320	270	205	205	170	170	80	Φ25	22	Φ34	10	80	37.3
2	EHS80-270	125	80	300	300	385	300	685	505	315	140	320	270	205	205	170	170	80	Φ25	22	Φ34	10	80	37.3
3	EHS80-370	125	80	330	330	385	300	685	540	315	140	320	270	205	205	170	170	80	Φ25	22	Φ34	10	80	37.3
4	EHS100-250	150	100	330	330	385	300	685	545	355	170	320	270	235	235	200	200	80	Φ25	22	Φ34	10	80	37.3
5	EHS100-310	150	100	330	330	385	300	685	585	355	170	320	270	235	235	200	200	80	Φ25	22	Φ34	10	80	37.3
6	EHS100-375	150	100	370	370	385	300	685	610	355	170	320	270	235	235	200	200	75	Φ25	22	Φ34	10	80	37.3
7	EHS125-230	200	125	370	370	485	365	850	620	400	200	390	340	265	265	225	225	90	Φ25	22	Φ44	12	110	47.3
8	EHS125-290	200	125	370	370	485	365	850	635	400	200	390	340	265	265	225	225	90	Φ25	22	Φ44	12	110	47.3
9	EHS125-365	200	125	370	370	485	365	850	660	400	200	390	340	265	265	225	225	90	Φ25	22	Φ44	12	110	47.3
10	EHS125-500	200	125	450	450	485	365	850	715	400	200	390	340	320	320	280	280	85	Φ25	22	Φ44	12	110	47.3
11	EHS150-290	200	150	400	400	485	365	850	655	400	200	390	340	265	265	225	225	90	Φ25	22	Φ44	12	110	47.3
12	EHS150-360	200	150	400	400	485	365	850	670	400	200	390	340	265	265	225	225	90	Φ25	22	Φ44	12	110	47.3
13	EHS150-460	200	150	450	450	520	400	920	710	400	200	480	430	315	315	280	280	75	Φ30	35	Φ54	16	110	58.3
14	EHS150-605	200	150	600	500	520	400	920	885	500	300	480	430	390	390	350	350	95	Φ30	35	Φ54	16	110	58.3
15	EHS200-250	250	200	450	450	520	400	920	780	500	240	480	430	315	315	280	280	85	Φ25	25	Φ54	16	110	58.3
16	EHS200-320	250	200	450	450	520	400	920	800	500	240	480	430	315	315	280	280	85	Φ25	25	Φ54	16	110	58.3
17	EHS200-420	250	200	500	500	520	400	920	820	500	240	480	430	330	330	280	280	100	Φ25	25	Φ54	16	110	58.3
18	EHS200-520	250	200	600	600	614	464	1078	920	560	300	490	430	400	400	350	350	100	Φ28	28	Φ64	18	140	68.4
19	EHS200-670	250	200	650	550	614	464	1078	920	600	350	500	400	400	400	350	350	110	Φ30	35	Φ64	18	140	68.4
20	EHS250-280	300	250	500	500	614	464	1078	940	600	300	480	400	400	400	350	350	100	Φ30	28	Φ64	18	140	68.4
21	EHS250-370	300	250	500	500	614	464	1078	945	600	300	480	400	400	400	350	350	100	Φ30	28	Φ64	18	140	68.4
22	EHS250-480	300	250	550	550	695	515	1210	950	600	300	600	520	400	400	350	350	100	Φ30	32	Φ74	20	170	78.9
23	EHS250-600	300	250	650	550	695	515	1210	1050	630	350	600	520	400	400	350	350	110	Φ30	35	Φ74	20	170	78.9
24	EHS300-300	350	300	550	500	614	464	1078	1000	630	300	500	400	400	400	350	350	100	Φ30	30	Φ64	18	140	68.4
25	EHS300-435	350	300	650	550	695	515	1210	1050	670	350	600	520	400	400	350	350	100	Φ30	32	Φ74	20	170	78.9
26	EHS300-560	400	300	700	650	765	585	1350	1135	710	350	620	520	525	525	475	475	110	Φ30	35	Φ84	22	170	89.4
27	EHS300-700	400	300	750	650	765	585	1350	1235	750	400	620	520	530	530	475	475	120	Φ30	40	Φ84	22	170	89.4
28	EHS350-305	400	350	650	550	695	515	1210	1060	670	350	600	520	400	400	350	350	100	Φ30	32	Φ74	20	170	78.9
29	EHS350-360	400	350	650	550	695	515	1210	1090	670	350	600	520	400	400	350	350	100	Φ30	32	Φ74	20	170	78.9
30	EHS350-430	450	350	750	650	765	585	1350	1165	750	400	600	520	530	530	475	475	120	Φ30	35	Φ84	22	170	89.4
31	EHS350-510	400	350	700	650	765	585	1350	1185	750	400	620	520	525	525	475	475	110	Φ30	40	Φ84	22	170	89.4
32	EHS350-660	450	350	750	650	765	585	1350	1255	780	400	620	520	530	530	475	475	120	Φ30	40	Φ84	22	170	89.4
33	EHS400-410	500	400	700	550	840	655	1495	1205	800	400	750	650	420	420	370	370	120	Φ33	40	Φ75	20	170	79.9
34	EHS400-460	500	400	650	550	840	655	1495	1225	800	400	750	650	520	520	470	470	120	Φ33	40	Φ75	20	170	79.9
35	EHS400-520	500	400	750	650	765	585	1350	1380	900	450	700	600	550	550	500	500	120	Φ33	45	Φ84	22	170	89.4
36	EHS400-680	500	400	750	650	895	670	1565	1390	850	450	720	650	500	500	440	440	150	Φ33	40	Φ95	25	210	100.4
37	EHS500-510	600	500	850	750	940	755	1695	1490	950	475	900	600	560	560	500	500	150	Φ42	60	Φ85	22	170	90.4
38	EHS500-640	600	500	850	750	940	755	1695	1490	950	470	900	600	560	560	500	500	150	Φ42	60	Φ85	22	170	90.4
39	EHS500-700	600	500	1000	850	935	710	1645	1630	1050	550	790	660	720	720	660	660	150	Φ42	60	Φ105	28	210	111.4
40	EHS500-790	600	500	1000	900	1078	810	1888	1760	1100	600	1000	900	710	710	650	650	150	Φ42	60	Φ115	32	220	122.4
41	EHS500-890	600	500	1050	950	1078	810	1888	1855	1150	650	1000	900	710	710	650	650	150	Φ42	60	Φ115	32	220	122.4
42	EHS600-540	700	600	1100	900	940	755	1695	1695	1100	560	910	790	705	705	650	650	150	Φ42	60	Φ85	22	170	90.4
43	EHS600-620	700	600	1000	1000	1025	800	1825	1725	1100	545	950	850	725	725	665	665	150	Φ42	60	Φ105	28	210	111.4
44	EHS600-710	700	600	1000	1100	1078	810	1888	1710	1050	545	1020	900	710	710	650	650	150	Φ42	50	Φ115	32	220	122.4
45	EHS600-830	700	600	1100	1200	1130	855	1985	1850	1150	650	970	820	710	710	650	650	150	Φ42	60	Φ125	32	250	132.4

### Structure Drawing

- No. Spare Part**
- Casing
  - Casing Cover
  - Wear Ring
  - Impeller
  - Seal Housing
  - Bearing Cover
  - Drive End Bearing Housing
  - Non-drive End Bearing Housing
  - Lock Nut
  - Bearing Baffle
  - Seal Plate
  - Seal Cover
  - Mechanical Seal
  - Shaft
  - Shaft Sleeve
  - Bearing Pressing Ring
  - Packing Pressing Ring
  - Seal Cage
  - Gland Packing
  - Gland Cover

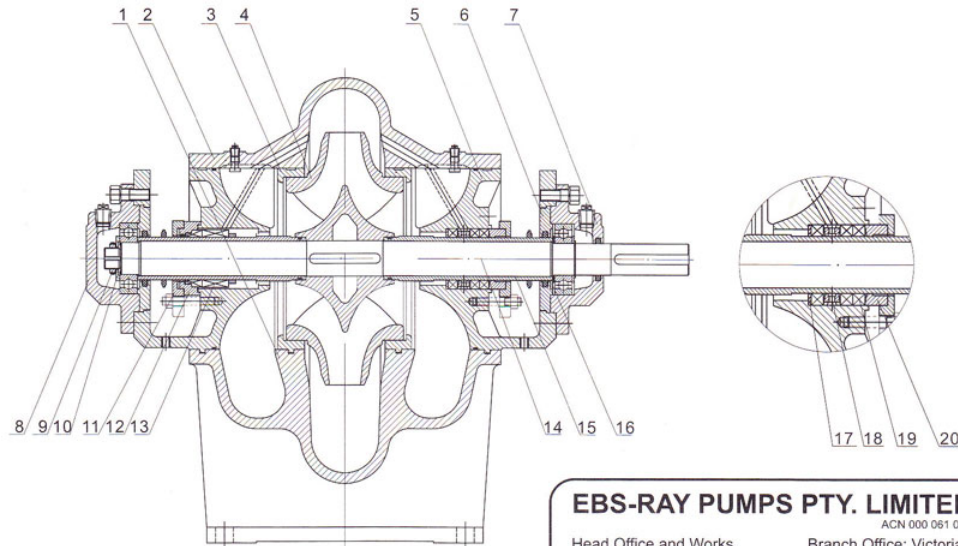

### EBS-RAY PUMPS PTY. LIMITED

ACN 000 061 003

Head Office and Works  
628 Pittwater Road  
Brookvale NSW 2100  
Australia.

Branch Office: Victoria  
Phone: (03) 9706 7263  
Fax: (03) 9706 7312

Phone: (02) 9905 0234  
Fax: (02) 9938 3825

Branch Office: Queensland  
Phone: (07) 3260 7411  
Fax: (07) 3260 7422